

# CPD 08/10/12 SH



## 0.8-1.2 t

### G2 series Three wheel AC Battery Forklift Truck



**ANHUI HELI CO., LTD.**

Add / No.668, FangXing Road, Hefei, China  
Fax / +86-551-63639966  
Tel / +86-551-63639068(America); 63639258(Europe); 63639358(Asia);  
63662105(Africa & Middle East); 63639530(Overseas Marketing)



LinkedIn



YouTube



Facebook

Design&Print:shell Printing 20220916

\* Our products are subject to improvements and changes without notice.

## Flexible operations in tight spaces

It has light weight and can enter the cargo elevator together with the goods.



The variable wheelbase design of the front axle can increase the stability of the whole truck and make driving safer when it is extended; when retracted, it has better mobility and more convenient operation in tight space.



The truck features small dimensions, **90°** turning of rear wheel, small turning radius and flexible operation which to permit maneuvering in tight space.



## Rich configurations

EPS electronic steering system is equipped as standard, which makes steering more smart, operation more accurate and driving experience more fluent.

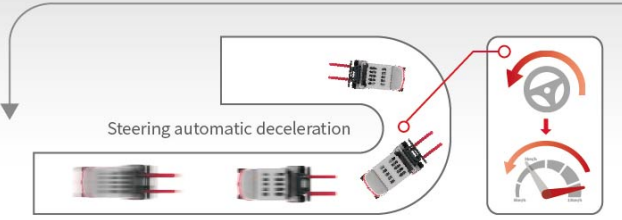

Standard configuration of steering deceleration offers automatic proportional deceleration on the curve to ensure the smooth driving of the truck when passing the curve.



Ergonomic integrated operation platform offers complete functions and convenient operation.

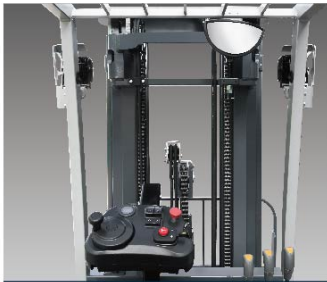

Wide view mast offers wide view.



Rear handle with horn ensures stable driving posture when reversing and driving safety and comfort.



Turn signal switch Forward /Reverse switch

## Convenient and high efficient maintenance

- Battery side pulling changing way makes battery changing more convenient.
- Full opening of cab offers convenient assembling and disassembling and good maintainability.



## Safe and reliable

- Imported electronic elements have reliable quality.
- The truck has the functions of regenerated braking, plug braking and anti-slip on slope and they are safe and reliable.
- The truck is equipped with LED lights and polyurethane tyre and they are durable.
- High frequent MOSFET integrated controller makes controls on truck travelling and lifting more accurate.

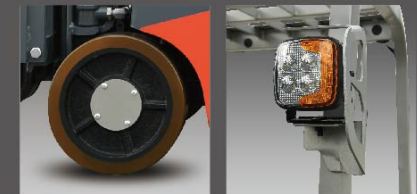

## Standard configuration

- Wide view basic mast
- Standard fork
- II stage fork arm carrier
- Control valve
- Battery
- Seat
- LED display
- Polyurethane tyre
- LED light
- Traction pin
- Turn automatic deceleration function
- Electric power steering
- Battery side pulling

## Optional device

- Three-stage full free lift mast
- Battery roller stand
- Side shifting
- Warning light (flashing, rotating, buzzing)
- Rear working light
- Fan
- Fire extinguisher
- Heli smart fleet management system

**Manufacturer and Technical Data**

Characteristics					
<b>Manufacturer</b>					
1.02 Model			CPD08SH	CPD10SH	CPD12SH
1.03 Configuration number			GA1	GA1	GA1
1.04 Rated capacity	Q	kg	800	1000	1200
1.05 Load center distance	c	mm	400	400	400
1.06 Power mode				Battery	
1.07 Driving mode				Seated	
1.08 Front overhang	x	mm	225		225
1.09 Wheelbase	y	mm	980/888	1142/1050	1142/1050
<b>Weight</b>					
2.01 Total weight (with/without battery)		kg	1685/1445	1790/1468	1930/1540
2.02 Axle load (laden,front/rear)		kg	2160/325	2440/350	2750/380
2.03 Axle load (unladen,front/rear)		kg	800/885	825/945	840/1090
<b>Tyres</b>					
3.01 Tyre type				Polyurethane	
3.02 Tyre size,front			φ285×100	φ285×100	φ285×100
3.03 Tyre size,rear			φ250×100	φ250×100	φ250×100
3.04 Wheels,number front/rear (x=driven wheels)			2/1X	2/1X	2/1X
3.05 Tread, front	b <sub>10</sub>	mm	750	750	750
<b>Dimensions</b>					
4.01 Mast tilt angle (forward/backward)	α/β	°	3/5	3/5	3/5
4.02 Height (mast lowered)	h <sub>1</sub>	mm	2000	2000	2000
4.03 Free lifting height	h <sub>2</sub>	mm	60	60	60
4.04 Lifting height (standard)	h <sub>3</sub>	mm	3000	3000	3000
4.05 Max. height,extended (with backrest)	h <sub>4</sub>	mm	4016	4016	4016
4.06 Height of overhead guard	h <sub>5</sub>	mm	1900	1900	1900
4.07 Seat height relating to SIP (to ground)	h <sub>7</sub>	mm	886	886	886
4.08 Towing coupling height	h <sub>10</sub>	mm	390	390	390
4.09 Overall length (with fork)	l <sub>1</sub>	mm	2133	2295	2295
4.10 Overall length (without fork)	l <sub>2</sub>	mm	1363	1525	1525
4.11 Overall width	b <sub>1</sub>	mm	850	850	850
4.12 Fork size:thickness x width x length	s/e/l	mm	32×100×770	32×100×770	32×100×770
4.13 Fork carriage,according to ISO2328			2A	2A	2A
4.14 Distance across fork-arms,Max./Min.	b <sub>3</sub>	mm	760/200	760/200	760/200
4.15 Distance across fork-arms,Max./Min.	m <sub>1</sub>	mm	85	85	85
4.16 Ground clearance (center of wheelbase)	m <sub>2</sub>	mm	65	65	65
4.17 Right angle stacking aisle width for pallet 1000 x1200mm crossways	A <sub>st</sub>	mm	2530	2753	2753
4.18 Right angle stacking aisle width for pallet 800 x1200mm lengthways	A <sub>sl</sub>	mm	2692	2915	2915
4.19 Min. outside turning radius	W <sub>s</sub>	mm	1138	1300	1300
<b>Performance Data</b>					
5.01 Travel speed (laden/unladen)		km/h	6.5/8	6.5/8	6.5/8
5.02 Lift speed (laden/unladen)		m/s	0.15/0.235	0.15/0.235	0.15/0.235
5.03 Lowering speed (laden/unladen)		m/s	0.40/0.35	0.40/0.35	0.40/0.35
5.04 Max.drawbar pull (laden/unladen)		N	4000	4200	4500
5.05 Max.gradeability (laden/unladen)		%	12	10	8
5.06 Acceleration time(10 m)(laden/unladen)		s	8.1/7.8	8.1/7.8	8.1/7.8
<b>Battery</b>					
6.01 Battery voltage/Capacity		V/Ah	24/240	24/360	24/480
6.02 Battery weight (Min./Max.)		kg	240	320	390
6.03 Battery,according to DIN			43531A	43531A	43531A
<b>Motor and controller</b>					
7.01 Driving motor powering (S2-60min)		kW	2.6	2.6	2.6
7.02 Lifting motor powering (S3-15%)		kW	3.0	3.0	3.0
7.03 Driving motor controlling mode			MOSFET/AC	MOSFET/AC	MOSFET/AC
7.04 Lifting motor controlling mode			MOSFET/DC	MOSFET/DC	MOSFET/DC
<b>Addition data</b>					
8.01 Service brake/Parking brake				Hydraulic/Electromagnetic	
8.02 Operating pressure for attachments		Mpa	14.5	14.5	14.5

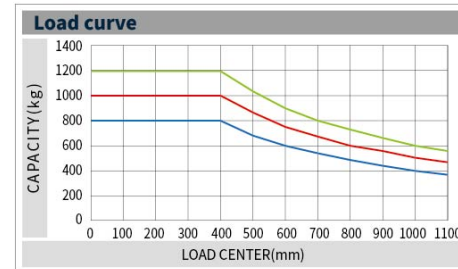
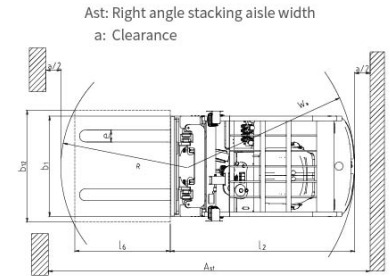
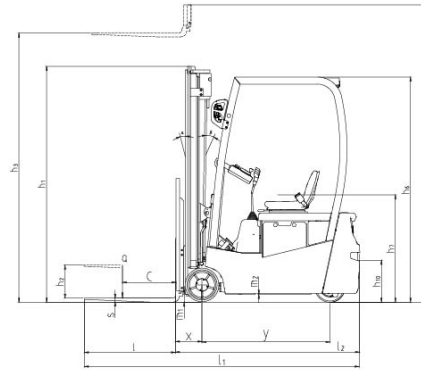

CPD08 CPD10 CPD12

**Note:**  
The vertical axis stands for load capacity and the horizontal axis stands for load center which is calculated from the front surface of the forks to the gravity of the standard load. the standard load means a cubic with 800mm edge length. When mast is tilted forward, using non-standard forks or loading large goods, the load capacity will be reduced. The load capacity of standard mast at different load center can be known from this load chart.

Mast model	Max.lifting height (mm)	Load capacity (ode center 400mm)(kg)			Height (mast lowered)(mm)	Free lift (with backrest) (mm)	Service weight (kg)			Mast tilt angle α/β (°)
		0.8t	1.0t	1.2t			0.8-1.2t	1.0t	1.2t	
M200	2000	800	1000	1200	1500	60	1634	1739	1879	3/5
M250	2500	800	1000	1200	1750	60	1658	1763	1903	3/5
M270	2700	800	1000	1200	1850	60	1669	1774	1914	3/5
M300	3000	800	1000	1200	2000	60	1685	1790	1930	3/5
M330	3300	800	1000	1200	2150	60	1701	1806	1946	3/5
M350	3500	700	900	1100	2250	60	1712	1817	1957	3/5
M370	3700	650	850	1000	2350	60	1723	1828	1968	3/5
M400	4000	550	750	850	2500	60	1759	1864	2004	3/5
M425	4250	500	650	750	2625	60	1772	1877	2017	3/5
M450	4500	450	550	650	2750	60	1786	1891	2031	3/5

Mast model	Max.lifting height (mm)	Load capacity (ode center 400mm)(kg)			Height (mast lowered)(mm)	Free lift (with backrest) (mm)	Service weight (kg)			Mast tilt angle α/β (°)
		0.8t	1.0t	1.2t			0.8-1.2t	1.0t	1.2t	
ZSM360	3600	650	850	1000	1682	748	1767	1872	2012	3/5
ZSM380	3800	600	750	900	1748	808	1778	1883	2023	3/5
ZSM400	4000	500	700	800	1814	868	1789	1894	2034	3/5
ZSM430	4300	450	600	700	1914	968	1805	1910	2050	3/5
ZSM450	4500	400	500	600	1980	1028	1815	1920	2060	3/5

Note: 442 mmFree lifting height without backrest:+442mm.